

Ventilating Fan Specifications

Model: FV-15EGS112

■ Specifications

			110V 60Hz	120V 60Hz	127V 60Hz
			Exhaust	Exhaust	Exhaust
Air Volume	m ³ /h	±10%	160	170	178
Power Consumption	W	±20%	7.0	8.1	8.8
Ampere	A	±20%	0.066	0.070	0.073
Noise	dB (A)	+3/-7	38.5	40.0	40.5
*Rotation Speed	min ⁻¹		2441	2580	2653

• This specifications are specified with duct sleeve , duct spinner and pipe hood.

*Rotation Speed data are reference only.

1. Power Rating ----- 110-127V~ 60Hz
2. Motor Type ----- Capacitor start and run induction motor
3. Blade Type ----- 130mm dia. propeller fan
4. Ambient Temperature ----- -10 to 40 deg.C
5. Insulation Resistance ----- More than 10meg ohm
6. Electrical Strength ----- 1500V~ 1 minute
7. Net Weight ----- 1.1Kg
8. Insulation Class ----- Class E
9. Type of insulation ----- Functional insulation

(Required from SASO 112)

■ Drawing with dimensions (Unit: mm)

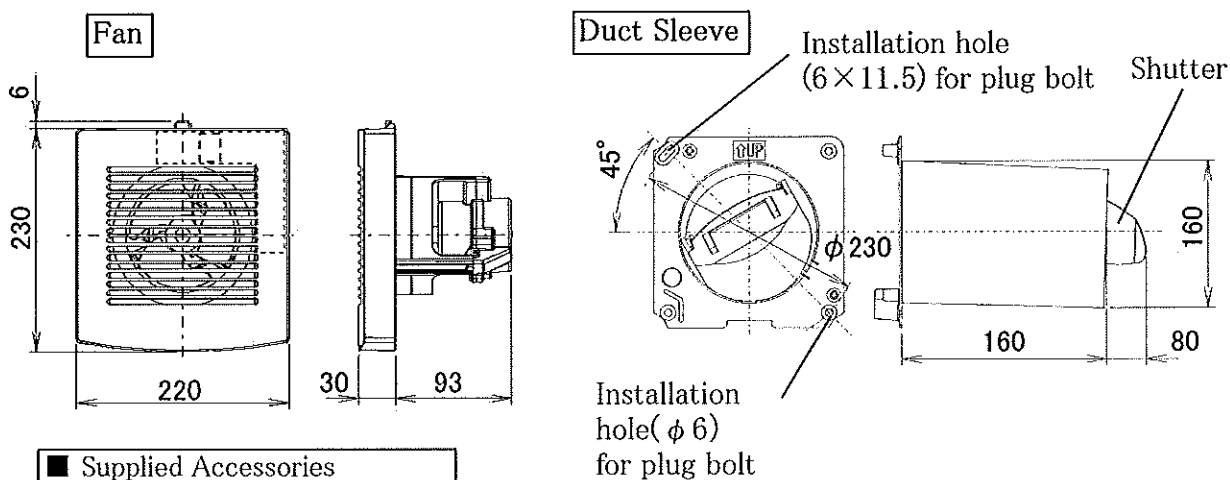

■ Supplied Accessories

- Plug bolt : 2 pcs
- Screw : 2 pcs (for plug bolt)
- Screw : 2 pcs (for Fan)
- Operating Instruction : 1 pcs
- Installation Instruction : 1 pcs

- Hole size: ϕ 165~170mm

■ Circuit diagram

